





# Hillsborough County Florida

SM

## STAFF REPORT



### Project Location Map

**PRS 21-0254**

Folio: 57481.0990

- Application Site
- Parcels



0 100 200 Feet

STR: 16-32-19, 15-32-19

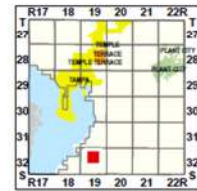

NOTE: Every reasonable effort has been made to ensure the accuracy of this map. Hillsborough County does not assume any liability arising from use of the map. This map is provided without warranty of any kind, either expressed or implied. Accuracy is not intended to be the subject of any contract or agreement. SOURCE: This map has been prepared for the inventory of the property located within Hillsborough County and is compiled from recorded deeds, plans, and other public records. It has been based on BEST AVAILABLE data.

Users of this map are hereby notified that the aforementioned public property information sources should be consulted for verification of the information depicted on this map.

Date: 01/09/2021 File: G:\2014\NO-06\Case-026.apx

## Application Review Summary and Recommendation

### 1.0 Summary

#### 1.1 Project Narrative

The request is to modify Planned Development (PD) 03-0525 associated with one parcel totaling approximately 2.4 acres to amend a condition allowing housing types for affordable housing development on the subject site in accordance with Land Development Code (LDC) 6.11.07, Affordable Housing Development. The parcel is currently approved for BPO zoning district uses or single-family residential. The request would allow other residential housing types as allowed for affordable housing per LDC 6.11.07. The site is located approximately 70 feet southwest of the Southeast 14<sup>th</sup> Avenue and Southeast 24<sup>th</sup> Street intersection. The underlying future land use (FLU) category of the subject parcel is Residential-4 (RES-4).

#### 1.2 Compliance Overview with Land Development Code (LDC) and Technical Manuals

An LDC 6.04.02.B Administrative Variance Request from LDC Section 6.04.03.L governing the substandard road improvements requirement for Southeast 24<sup>th</sup> Street has been requested at this time.

In addition, LDC Part 3.22.00., Ruskin Community Character Guidelines, states that the purpose of this part of the LDC is to provide for evaluation of rezonings for residential uses for consistency with the character of the neighborhood areas identified in the Ruskin Community Plan. Planned Development zonings approved prior to adoption of the regulations are exempt, however, any subsequent modification to the PD the area associated with the modification is to be reviewed for compliance with the guidelines. The parcel is located in Area 3 of the Ruskin Community plan and projects less than 50 acres in the RES-4 Future Land Use designation are required to have single-family lots with a minimum lot size of 6,000 square feet with a minimum of 20 percent of the lots having a lot width of 60 feet and all other lots having a minimum lot size of 55 feet. The parcel subject to the modification is currently allowed residential on 5000 square foot lots and the proposal revisions to allowed housing types and design is not consistent with the allowed residential type of the respective neighborhood area. Therefore, per LDC subsection 3.22.03.C. if a proposed application is inconsistent with the Neighborhood Character Review Guidelines shall provide a justification statement with the application submittal with sufficient data and analysis to demonstrate compliance with the review standards herein. The applicant shall be required to demonstrate the project furthers the intent of the Ruskin Community Plan, is innovative, creative and not simply a deviation from the Guidelines for the purpose of maximizing entitlements.

The applicants submitted justification states that this property was intended as an Affordable Housing Development project and was developed under the mutual self help housing program created in 1963 by the United States Department of Agriculture (USDA). Under this program, low income program recipients obtain mortgages through the USDA at below market rates. The approved buyers then work on their home doing semi-skilled and unskilled labor tasks. These families create sweat equity in their homes and have an opportunity to become homeowners for a price that they can afford. However, Hillsborough County, and the Ruskin / south County area in particular, has experienced rapid increases in construction cost. As a result, per the applicant, development of single family detached housing would result in costs that exceed what these families could afford, even under this program. Furthermore, the applicant states they have developed a design which will further the intent of the Ruskin Community Plan. Goal 5 of the Plan, Community and Neighborhood Character, is to provide for a diversity of home styles and types while protecting Ruskin's small town character. The strategies recommended to achieve this goal include the

development of housing to accommodate a diverse population and income levels, which the applicant state is what is proposed by this development. The applicant further indicates that through coordination with Transportation staff, they have developed an innovative and creative layout which utilizes rear alley vehicular access to situate homes near the right of way with pedestrian access to the surrounding sidewalks. This layout will create a small town neighborhood character with individual sidewalks to each unit while limiting individual driveways onto the surrounding roadway system in keeping with current access management guidelines.

Staff has evaluated the applicant's justification statement and finds the applicant's justification of the request sufficient and demonstrates that the project furthers the intent of the Ruskin Community Plan.

### **1.3 Analysis of Recommended Conditions**

Specifically, the main proposed amendment is to condition number 5 to allow for other residential housing types subject to affordable housing development standards and minimum setback requirements on the subject site. The other proposed amendments include transportation related conditions based on the subject request.

### **1.4 Evaluation of Existing and Planned Public Facilities**

The site is located within the Urban Service Area where potable water and wastewater services are provided by Hillsborough County. An 8-inch potable water main exists approximately 65 feet from the site. A 6-inch wastewater force main exists and is located adjacent to the site. Therefore, the site is required to connect to the publicly owned and operated potable water and wastewater systems in accordance with the requirements of the LDC. The developer is responsible for submitting a utility service request at the time of development plan review and will be responsible for any on-site improvements as well as possible off-site improvements.

Transit service is conveniently located to service this site. The closest transit stop is located 0.2 miles away just west of the intersection of Southeast 14<sup>th</sup> Avenue and Southeast 21<sup>st</sup> Street.

The subject property is located adjacent to Southeast 14<sup>th</sup> Avenue and Southeast 24<sup>th</sup> Street. Southeast 14<sup>th</sup> Avenue is a 2-lane, undivided, substandard collector roadway. Sidewalks are present on Southeast 14<sup>th</sup> Avenue. However, no turn lanes, gutters, bicycle lanes, median, and paved shoulders are present on this roadway. Southeast 24<sup>th</sup> Street is a 2-lane, undivided, substandard collector roadway. A sidewalk is present on Southeast 24<sup>th</sup> Street. However, no turn lanes, gutters, bicycle lanes, median, and paved shoulders are present on this roadway.

Transportation staff has reviewed the application and offers no objections, subject to the listed conditions. Their review notes that there is no change in the overall maximum entitlements, as such, staff anticipates that this request will have no change in the overall trip generation potential of the subject site. At the request of staff, the applicant modified the existing plan to reflect access which was constructed, as well as eliminate access connection within the vacant portion of the PD (folio 57481.0990) which do not meet access spacing requirements per the LDC and which otherwise cause the project to exceed the maximum number of allowable access points pursuant to Section 6.04.03.I of the LDC. Staff supports these changes. The applicant provided a transportation analysis indicating the remaining access points are not currently exceeding, nor are anticipated to exceed, the Section 6.04.04.D. LDC turn lane warrants.

The applicant's Engineer of Record (EOR) submitted a Section 6.04.02.B. Administrative Variance Request (dated March 25, 2021) from the Section 6.04.03.L. LDC requirement, whereby the developer is required

to improve Southeast 24<sup>th</sup> Street (between the project roadway and nearest roadway meeting County standards) to current County standards for a TS-4 or TS-7 collector roadway. Based on factors presented in the Administrative Variance Request, the County Engineer found the request approvable on May 25, 2021. If the rezoning is approved, the County Engineer will approve the above referenced Administrative Variance Request, upon which the developer will not be required to make improvements to the roadway.

### **1.5 Environmental/Natural Resources**

The Environmental Protection Commission (EPC) reviewed the request and finds that no wetland or other surface water areas exist on the site.

### **1.6 Comprehensive Plan Consistency**

The site is located within the RES-4 FLU category and the Ruskin Community Plan Area.

### **1.7 Compatibility**

The site is located in an area comprised of cultural/institutional and residential uses. A majority of the area is located within the RES-4 FLU category, which is suitable for low density residential development. The overall area is also within the Hillsborough County Urban Service Area.

As shown in Exhibit 2, the site is adjacent to properties zoned PD (to the south and west), but within the general area there are properties zoned PD (to the north), ASC-1, RSC-2, and RSC-6 (to the northeast), AS-1 (to the northeast and east), and AR (to the northwest).

The subject parcel is a part of the larger development area within the PD totaling approximately 47.9 acres. A majority of the larger development area is approved for single-family conventional dwelling units. However, the subject parcel is within the portion of the larger development area that is approved for Business, Professional Office, child care center, and single-family residential uses.

Per LDC subsection 6.11.07.B.1, for zoning districts that permit lot size of less than 7,000 square feet, affordable housing projects are permitted to develop with any type of housing type (i.e. duplex, tri-plex, quadraplex, townhomes, multi-family). The minimum lot size for the subject PD for single-family is 5,000 square feet.

Based on the above considerations, staff finds the proposed modification to PD 03-0525 compatible with the existing zoning districts and development pattern in the area.

### **1.8 Agency/Department Comments**

The following agencies and departments reviewed the request and offer no objections:

- Water Resource Services
- Environmental Protection Commission
- Transportation

### **1.9 Exhibits**

Exhibit 1: Project Aerial

Exhibit 2: Zoning Map

Exhibit 3: Site Plan

## **2.0 Recommendation**

Based on the above considerations, staff recommends approval of the request.

**Approval** - Approval of the request, subject to the conditions listed below, is based on the revised site plan received July 6, 2021.

1. The project shall be permitted a maximum of 239 single-family conventional residential dwelling units. The development standards shall be as follows unless otherwise referenced herein:

- Minimum lot size – 5,000 square feet
- 28 lots – minimum 4,000 square feet (interior lots)
- Front yard setback – 10 feet, garages 20 feet
- Rear yard setback – 20 feet
- Side yard setback – 5 feet
- Maximum height – 35 feet
- Maximum lot coverage – 50 percent

2. The project shall be permitted a maximum of 15,000 square feet of Business, Professional Office (BPO) uses in the area designated on the site plan. These areas shall be developed in accordance with BPO zoning district standards, unless otherwise specified herein. Buildings shall be limited to a maximum size of 5,000-square-foot buildings and shall be residential in character, including pitched roofs.

3. The project shall be permitted a maximum 75-student child care center, subject to the Land Development Code (LDC) Section 6.11.24 Child Care Center design standards. The square footage for the child care center shall be deducted from that approved for the BPO use.

4. The project shall be permitted a community center/recreational facilities.

5. The areas designated for BPO uses shall be permitted to be converted to single-family residences, which in accordance with the single-family developed standards outlined herein and shall count towards the maximum number of permitted residential units, and shall be subject to LDC Section 6.11.07, Affordable Housing Development Standards, except that:

- Residences with rear alley vehicular access and front pedestrian connections to the surrounding public sidewalks shall be provided and shall be subject to the following minimum setback requirements:
  - a. Front yard setback – 10 feet
  - b. Rear yard setback – 20 feet
  - c. Side yard setback – 5 feet.

These residential units shall be permitted BPO uses as an accessory use. BPO uses shall be developed in accordance with LDC Section 6.11.48. Home Occupation, except that Sections 6.11.48.H. and 6.11.48.I. shall not apply.

6. Exterior lighting within the project shall be of fully shielded.

7. The developer shall construct a minimum of one (1) vehicular and pedestrian connection between development within folio 57481.0990 and Unity Village Drive.

8. If PRS 21-0254 is approved, the County Engineer will approve the Section 6.04.02.B. Administrative Variance (AV) (dated March 25, 2021) which was found approvable by the County Engineer (on May 25, 2021) for the reasons set forth in the AV request. Approval of this AV will waive the Southeast 24<sup>th</sup> Street substandard road improvements required by Section 6.04.03.L of the LDC.

9. Prior to PD Site Plan Certification, the applicant shall revise the PD site plan to:

- Align the proposed access from folio 57481.0990 with an existing access on the east side of Southeast 24<sup>th</sup> Street;
- Revise the vehicular circulation pattern within folio 57481.0990 such that it connects with Unity Village Drive in a minimum of one location; and,
- Revise the site data table such that it eliminates "CN" uses as an allowable use (this change was never requested).

710. Approval of this rezoning application does not ensure that water will be available at the time when the applicant seeks permits to actually develop.

811. In the event there is a conflict between a zoning condition of approval, as stated herein, and any written or graphic notation on the general site plan, the more restrictive requirement shall apply.

912. Approval of this rezoning petition by Hillsborough County does not constitute a guarantee that the Environmental Protection Commission approvals/permits necessary for the development as proposed will be issued, does not itself serve to justify any impacts to wetland, and does not grant any implied or vested right to environmental approvals.

103. Development of the project shall proceed in strict accordance with the terms and conditions contained in the Development Order, the General Site Plan, the land use conditions contained herein, and all applicable rules, regulation and ordinances of Hillsborough County.

114. Within 90 days of approval of RZ 03-0525 by the Hillsborough County Board of County Commissioners, the developer shall submit to the Planning and Growth Management Department a revised General Development Plan for certification reflecting all the conditions outlined above.

125. Effective as of February 1, 1990, this development order/permit shall meet the concurrency requirements of Chapter 163 Part II, Florida Statutes. Approval of this development order/permit does not constitute a guarantee that there will be public facilities at the time of application for subsequent development orders or permits to allow issuance of such development orders or permits.

APPLICATION: PRS 21-0254

ZHM HEARING DATE:

BOCC MEETING DATE: July 20, 2021

CASE REVIEWER: Kevie Defranc

**Staff's Recommendation: Approvable, Subject to Conditions**

Zoning  
Administrator  
Sign-off:



IntegriSign<sup>®</sup>  
Desktop  
dy J. Brian Gray  
Tue Jul 6 2021 13:15:14



EXHIBIT 1



Project Location Map

PRS 21-0254

Folio: 57481.0990

- Application Site
- Parcels



0 150 300 Feet

STR: 16-32-19, 15-32-19

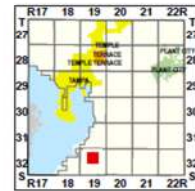

NOTE: Every reasonable effort has been made to ensure the accuracy of the map. Hillsborough County does not assume any liability arising from use of this map. This data is provided "as is" without warranty of any kind, either expressed or implied, including, but not limited to, the implied warranties of merchantability and fitness for a particular purpose.

SOURCE: This map has been prepared for the convenience of the property owner within Hillsborough County and is compiled from recorded deed, plan, and other public records. It has been based on BEST AVAILABLE data.

Users of this map are hereby notified that the aforementioned public property information sources should be consulted for verification of the information contained on this map.

Date: 01/05/2021 File: G:\2020\10-06\DelSite.aprx

EXHIBIT 2



---

APPLICATION: PRS 21-0254  
ZHM HEARING DATE:  
BOCC MEETING DATE: July 20, 2021

---

CASE REVIEWER: Kevie Defranc

---

**EXHIBIT 3**

SEE ATTACHED



LANDIS EVANS  
+ PARTNERS  
www.landisevans.com

3810 NORTHDALE BLVD.,  
SUITE 100  
TAMPA, FLORIDA 33624  
OFFICE: 813-949-7449  
FBPE CERT. OF AUTH. #4548

MARK	DATE	REVISION DESCRIPTION
1	5/26/21	REVISED PER TRANSPORTATION COMMENTS

PREPARED FOR:  
**HOMES FOR HILLSBOROUGH**

GENERAL DEVELOPMENT PLAN  
BAYOU PASS SUBDIVISION  
RUSKIN, HILLSBOROUGH COUNTY, FLORIDA

ENGINEER OF RECORD  
DESIGNED BY:  
DRAWN BY: CWC  
CHECKED BY: JDE  
PROJECT NO: 1622-19

VERT. DATUM:  
PRs 21-0254

SHEET NUMBER:  
**1 OF 2**



VICINITY MAP  
N.T.S.

**LEGAL DESCRIPTION**  
LOTS 338, 339, 340, 345 & 346; TOGETHER WITH THE NORTH 1/2 OF THE 40 FOOT PLATTED RIGHT-OF-WAY LYING SOUTH OF ADJACENT TO AND ABUTTING THE SOUTH BOUNDARY OF AFORESAID LOTS 345 AND 346 AND THE EAST 1/2 OF THE 40 FOOT PLATTED RIGHT-OF-WAY LYING WEST OF, ADJACENT TO AND ABUTTING THE WEST BOUNDARY OF AFORESAID LOTS 340 AND 345, RUSKIN COLONY FARMS AS RECORDED IN PLAT BOOK 103, PAGES 61 AND 63 OF THE PUBLIC RECORDS OF HILLSBOROUGH COUNTY, FLORIDA TOGETHER WITH THAT 20 FOOT BY 20 FOOT AREA AT THE SOUTHERN END OF THE NORTH-SOUTH RIGHT-OF-WAY AND AT THE WEST END OF THE EAST-WEST RIGHT-OF-WAY DESCRIBED ABOVE.

CONTAINING 49.1266 ACRES, MORE OR LESS.

**SITE DATA**

EXISTING ZONING:	PD
PROPOSED ZONING:	PD
EXISTING FLU:	R-4
MAX. DWELLING UNITS:	239
TOTAL PARCEL SIZE:	49.1266 AC
MAX. GROSS DENSITY:	4.865 (239 DU/49.1266)
TOTAL ALLOWED NON-RESIDENTIAL (DAYCARE, BP-O):	15,000 SF
FAR (NON-RESIDENTIAL) PER HILLSBOROUGH COUNTY LDC	
EXISTING ZONING NO.	PD 03-0525

NOTE: THERE ARE NO REQUESTED DEVIATIONS FROM PART 6.05.00, 6.06.00, OR 6.07.00 OF THE LAND DEVELOPMENT CODE.

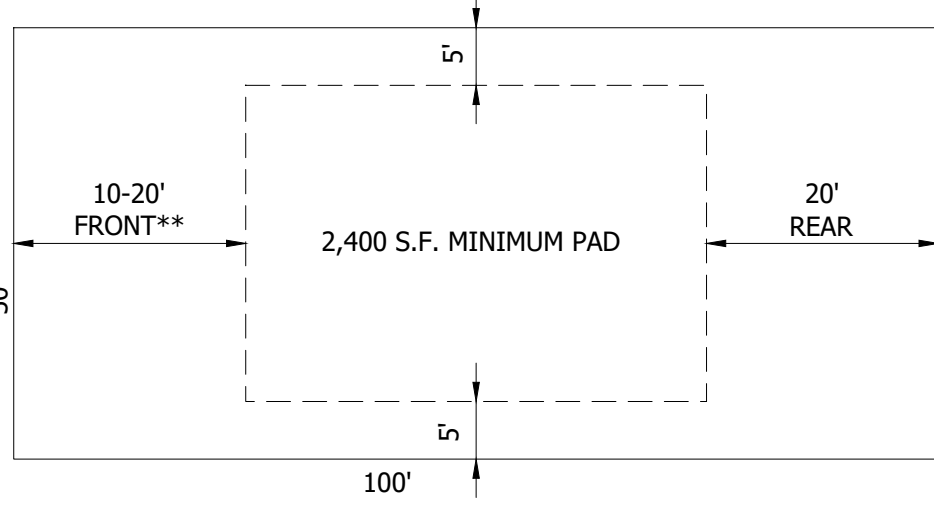

TYPICAL SINGLE FAMILY HOME LOT LAYOUT  
(NTS)

**PLANNING NOTES**

- PROPOSED DEVELOPMENT AREA, INCLUSIVE OF FOLIO 57481-0990, CONTAINS 49.1266 ACRES, MORE OR LESS.
- PROPOSED BUILDING & ASPHALT LOCATIONS ARE PRELIMINARY AND SUBJECT TO ENGINEERING, SOIL AND REGULATORY PERMIT REVIEWS. PROPOSED TREATMENT/ATTENUATION WILL BE PROVIDED IN THE DETENTION AREAS IN THE NORTHWEST AND SOUTHWEST PROPERTY CORNERS.
- PRELIMINARY AND CONSTRUCTION PLAN APPROVALS WILL BE SUBJECT TO REVIEW AGENCY COMMENTS.
- WATER & SANITARY SEWER SERVICE ARE AVAILABLE FROM HILLSBOROUGH COUNTY (URBAN SERVICE AREA).
- EXTERIOR LIGHTING WITHIN THE PROJECT SHALL PROCEED IN STRICT ACCORDANCE WITH THE TERMS AND CONDITIONS CONTAINED IN THE DEVELOPMENT ORDER, THE GENERAL SITE PLAN, THE LAND USE CONDITIONS CONTAINED HEREIN AND ALL APPLICABLE RULES, REGULATIONS AND ORDINANCES OF HILLSBOROUGH COUNTY.
- DEVELOPMENT OF THE PROJECT SHALL PROCEED IN STRICT ACCORDANCE WITH THE TERMS AND CONDITIONS CONTAINED IN THE DEVELOPMENT ORDER, THE GENERAL SITE PLAN, THE LAND USE CONDITIONS CONTAINED HEREIN AND ALL APPLICABLE RULES, REGULATIONS AND ORDINANCES OF HILLSBOROUGH COUNTY.
- GARBAGE DISPOSAL WILL BE CURBSIDE PICK-UP.
- LANDSCAPING SHALL BE PROVIDED PER SECTION 6.06.05 OF THE HILLSBOROUGH COUNTY LAND DEVELOPMENT CODE WITH APPLICABLE CREDITS FOR EXISTING VEGETATION AND PRESERVATION.
- MAXIMUM BUILDING HEIGHT TO BE 35'.
- PROPOSED SINGLE FAMILY DETACHED SETBACKS TO BE AS FOLLOWS:  
FRONT (RESIDENCE) AT 10'  
FRONT (GARAGE) AT 20'  
SIDE AT 5'  
REAR AT 20'
- PHASING OF CONSTRUCTION IS OPTIONAL TO DEVELOPER.
- PROPOSED DEVELOPMENT TO CONSIST OF 239± SINGLE FAMILY RESIDENCES, COMMUNITY CENTER, DAY CARE CENTER AND/OR AN OPTIONAL 15,000 SF PF C-N/BP-O USES.
- AREAS LABELED AS BP-O SHALL HAVE THE ALTERNATIVE OF BEING SINGLE FAMILY OR BP-O.
- NUMBER OF DAILY TRIPS PROJECTED TO TRAVEL ADJACENT STREETS AT EACH ACCESS POINT DETERMINED TO BE <5% OF THE LEVEL OF SERVICE "C" BY HILLSBOROUGH COUNTY TRANSPORTATION DEPARTMENT REP. GLENN SHOPMEYER.
- THE AREAS DESIGNATED FOR BPO USES SHALL BE PERMITTED TO BE CONVERTED TO SINGLE-FAMILY RESIDENCES UNDER THE FOLLOWING DEVELOPMENT OPTIONS:  
a. AS DUPLEX UNITS WITH THE FOLLOWING DIMENSIONS:  
FRONT: 10' WITH REAR ALLEY  
REAR: 20' WITH REAR ALLEY  
SIDE: 5'  
SINGLE FAMILY DEVELOPMENT WITHIN THE BPO USES SHALL COUNT TOWARD THE MAXIMUM NUMBER OF PERMITTED RESIDENTIAL UNITS. THESE RESIDENTIAL UNITS SHALL BE PERMITTED BPO USES AS AN ACCESSORY USE. BPO USES SHALL BE DEVELOPED IN ACCORDANCE WITH LDC SECTIONS 6.11.48. HOME OCCUPATION, EXCEPT THAT SECTIONS 6.11.48.H. AND 6.11.48.I. SHALL NOT APPLY.

**TRANSPORTATION NOTES**

- ALL ABANDONED DRIVEWAYS SHALL BE REMOVED AND CURBS RAISED TO HILLSBOROUGH COUNTY STANDARDS AND SPECIFICATIONS.
- ALL BROKEN SIDEWALKS SHALL BE RESTORED TO HILLSBOROUGH COUNTY STANDARDS AND SPECIFICATIONS.
- ANY DISTRIBUTED AREAS WITHIN THE RIGHTS-OF-WAY SHALL BE RESTORED TO HILLSBOROUGH COUNTY STANDARDS AND SPECIFICATIONS.
- CURB RAMPS SHALL BE PROVIDED WHERE THE PUBLIC SIDEWALK MEETS ALL DRIVEWAYS PER THE FLORIDA ACCESSIBILITY CODE STANDARDS AND SPECIFICATIONS.
- ALL SIGNAGE AND STRIPING TO COMPLY WITH THE MANUAL FOR UNIFORM TRAFFIC CONTROL DEVICES (M.U.T.C.D.)

**LANDSCAPING NOTES**

- NO UNDERGROUND UTILITIES INCLUDING IRRIGATION SHALL BE CONSTRUCTED WITHIN THE 10-FOOT PROTECTIVE RADIUS OF EXISTING TREES OR WITHIN THE 20-FOOT PROTECTIVE RADIUS OF GRAND TREES.
- NO SHADE TREES SHALL BE PLANTED WITHIN TWENTY FEET OF THE VERTICAL PLANE OF ABOVE GROUND UTILITY LINES.
- PROPOSED TREES AND SHRUBS SHALL BE FLORIDA GRADE #1 WITH SPECIFICATIONS AS FOLLOWS:  
TREES: 2" CALIPER MINIMUM; 8'-10' MIN. HEIGHT; 5'-6" MIN. SPREAD; 30 GALLON CONTAINER  
SHRUBS: TO BE PLANTED 3' ON CENTER; 24" MIN. HEIGHT; 24" MIN. SPREAD; 3 GALLON CONTAINER

**STORMWATER NOTES**

- EROSION/SEDIMENT CONTROL:  
CONTRACTOR IS TO PROVIDE EROSION CONTROL/SEDIMENTATION BARRIER (HAY BALES OR SILTATION CURTAIN) TO PREVENT SILTATION OF ADJACENT PROPERTY, STREETS, STORM SEWERS AND WATERWAYS. IN ADDITION, CONTRACTOR SHALL PLACE STRAW, MULCH OR OTHER SUITABLE MATERIAL ON GROUND IN AREAS WHERE CONSTRUCTION RELATED TRAFFIC IS TO ENTER AND EXIT SITE, IF, IN THE OPINION OF THE ENGINEER AND/OR LOCAL AUTHORITIES, EXCESSIVE QUANTITIES OF EARTH ARE TRANSPORTED OFF-SITE EITHER BY NATURAL DRAINAGE OR BY VEHICULAR TRAFFIC, THE CONTRACTOR IS TO REMOVE AND CLEAN SAID EARTH TO THE SATISFACTION OF THE ENGINEER AND/OR AUTHORITIES.
- RIGHT-OF-WAY PERMIT REQUIRED PRIOR TO INITIATING CONSTRUCTION WITHIN COUNTY RIGHT-OF-WAY. CONTACT JERRY TAYLOR, TRANSPORTATION DIVISION AT 276-8352.

**LEGEND**

ZONING DESIGNATION	<b>AR</b>
FUTURE LAND USE DESIGNATION	R-4
FOLIO NUMBER	0574811092
EXISTING OR FUTURE INGRESS/EGRESS ACCESS	↔
FUTURE INTERNAL ROAD	---

**ABBREVIATIONS**

PAVEMENT WIDTH	PW
UNDIVIDED	UD
DIVIDED	DI
RIGHT-OF-WAY	ROW

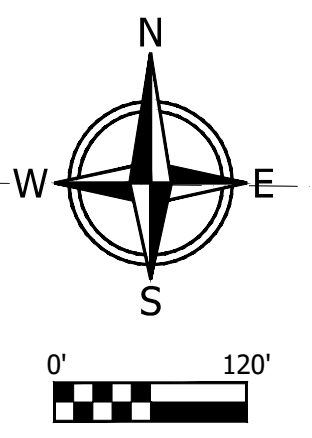
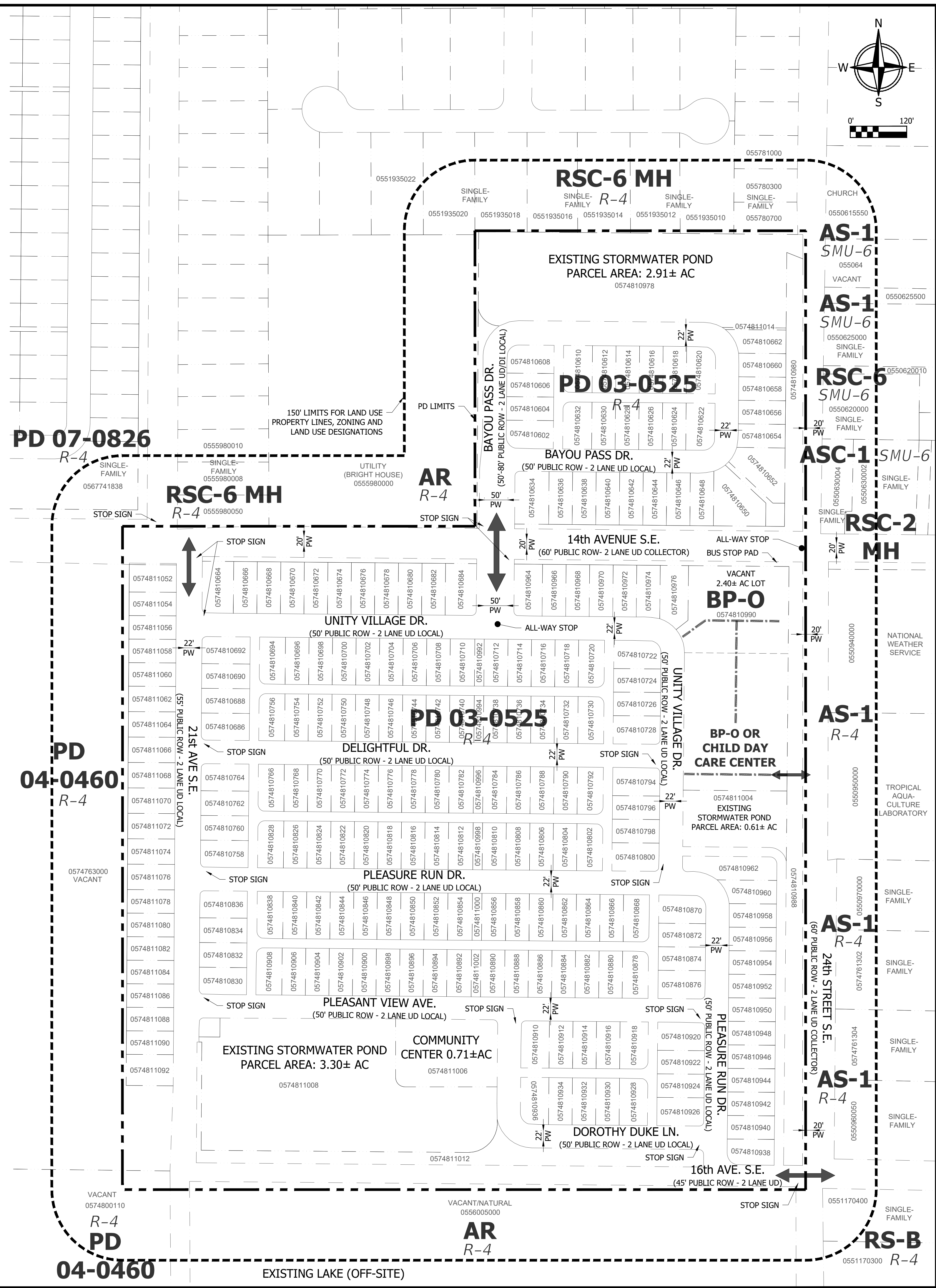



**CURRENTLY  
APPROVED**

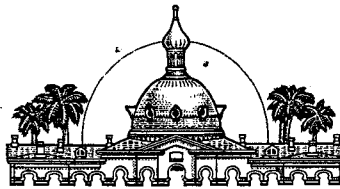

Hillsborough County  
Florida

Office of the County Administrator  
Daniel A. Kleman

August 14, 2003

BOARD OF COUNTY COMMISSIONERS

Kathy Castor  
Pat Frank  
Ken Hagan  
Jim Norman  
Jan K. Platt  
Thomas Scott  
Ronda Storms

Deputy County Administrator  
Patricia Bean

Assistant County Administrators  
Bernardo Garcia  
Kathy C. Harris

Homes for Hillsborough Inc.  
201 14<sup>th</sup> Ave. SE  
P O Box 771  
Ruskin FL 33570

RE: PETITION NO. RZ 03-0525 RU

Dear Applicant:

At the regularly scheduled public meeting on August 12, 2003, the Board of County Commissioners granted your request for rezoning of the tract of land described in your application from AR to PD, with the attached conditions.

The approval of a planned development rezoning requires the developer submit a revised General Site Plan reflecting all conditions, within 90 days of zoning approval. Failure to submit the site plans within the time period will place your rezoning in violation.

To comply with this requirement, please complete and submit the enclosed application for General Site Plan Review/Certification, to the Planning and Zoning Division, 20th floor of the County Center, 601 East Kennedy Boulevard. For information concerning the certification process, please contact Diane Gavitt at 272-5920.

Please keep this letter for your records. If we may be of service to you in the future, feel free to contact me at 272-5920.

Sincerely,

A handwritten signature in black ink that reads "Paula Harvey". The signature is written in a cursive, flowing style.

Paula M. Harvey, AICP, Director  
Planning and Zoning Division

Attachments

cc: Barry LeClair

**Approval** - Approval of the request, subject to the conditions listed below, is based on the general site plan submitted April 29, 2003.

1. The project shall be permitted a maximum of 239 single-family conventional residential dwelling units. The development standards shall be as follows unless otherwise referenced herein:
  - Minimum lot size – 5,000 square feet
  - 28 lots – minimum 4,000 square feet (interior lots only)
  - Front yard setback – 10 feet, garages 20 feet
  - Rear yard setback – 20 feet
  - Side yard setback – 5 feet
  - Maximum height – 35 feet
  - Maximum lot coverage – 50 percent
2. The project shall be permitted a maximum of 15,000 square feet of Business, Professional Office (BPO) uses in the area designated on the site plan. These areas shall be developed in accordance with BPO zoning district standards, unless otherwise specified herein. Buildings shall be limited to a maximum size of 5,000-square-foot buildings and shall be residential in character, including pitched roofs.
3. The project shall be permitted a maximum 75-student child care center, subject to the Land Development Code (LDC) Section 6.11.24 Child Care Center design standards. The square footage for the child care center shall be deducted from that approved for the BPO use.
4. The project shall be permitted a community center/recreational facilities.
5. The areas designated for BPO uses shall be permitted to be converted to single-family residences in accordance with the single-family developed standards outlined herein and shall count towards the maximum number of permitted residential units. These residential units shall be permitted BPO uses as an accessory use. BPO uses shall be developed in accordance with LDC Section 6.11.48. Home Occupation, except that Sections 6.11.48.H. and 6.11.48.I. shall not apply.
6. Exterior lighting within the project shall be of fully shielded.
7. Approval of this rezoning application does not ensure that water will be available at the time when the applicant seeks permits to actually develop.
8. In the event there is a conflict between a zoning condition of approval, as stated herein, and any written or graphic notation on the general site plan, the more restrictive requirement shall apply.



FINAL CONDITIONS  
OF APPROVAL

PETITION NUMBER: RZ 03-0525 RU  
BOCC MEETING DATE: August 12, 2003  
DATE TYPED: August 14, 2003

---

9. Approval of this rezoning petition by Hillsborough County does not constitute a guarantee that the Environmental Protection Commission approvals/permits necessary for the development as proposed will be issued, does not itself serve to justify any impacts to wetland, and does not grant any implied or vested right to environmental approvals.
10. Development of the project shall proceed in strict accordance with the terms and conditions contained in the Development Order, the General Site Plan, the land use conditions contained herein, and all applicable rules, regulation and ordinances of Hillsborough County.
11. Within 90 days of approval of RZ 03-0525 by the Hillsborough County Board of County Commissioners, the developer shall submit to the Planning and Growth Management Department a revised General Development Plan for certification reflecting all the conditions outlined above.
12. Effective as of February 1, 1990, this development order/permit shall meet the concurrency requirements of Chapter 163, Part II, Florida Statutes. Approval of this development order/permit does not constitute a guarantee that there will be public facilities at the time of application for subsequent development orders or permits to allow issuance of such development orders or permits.



# **AGENCY COMMENTS**

## AGENCY REVIEW COMMENT SHEET

---

---

TO: ZONING TECHNICIAN, Development Services Department

DATE: 5/25/2021

REVIEWER: James Ratliff, AICP, PTP

AGENCY/DEPT: Transportation

PLANNING AREA/SECTOR: RU

PETITION NO: PRS 21-0254

---

---

- This agency has no comments.
- This agency has no objection.
- This agency has no objection, subject to listed or attached conditions.
- This agency objects, based on the listed or attached conditions.

### **CONDITIONS OF APPROVAL**

#### *New Conditions:*

- The developer shall construct a minimum of one (1) vehicular and pedestrian connection between development within folio 57481.0990 and Unity Village Dr.
- If PRS 21-0254 is approved, the County Engineer will approve the Section 6.04.02.B. Administrative Variance (AV) (dated March 25, 2021) which was found approvable by the County Engineer (on May 25, 2021) for the reasons set forth in the AV request. Approval of this AV will waive the 24<sup>th</sup> St. SE substandard road improvements required by Section 6.04.03.L of the LDC.

#### *Other Conditions:*

- Prior to PD Site Plan Certification, the applicant shall revise the PD site plan to:
  - Align the proposed access from folio 57481.0990 with an existing access on the east side of 24<sup>th</sup> St.
  - Revise the vehicular circulation pattern within folio 57481.0990 such that it connects with Unity Village Dr. in a minimum of one location; and,
  - Revise the site data table such that it eliminates “CN” uses as an allowable use (this change was never requested).

### **DESCRIPTION OF REQUEST, STAFF ANALYSIS, AND CONCLUSION**

The applicant is requesting a personal appearance (PRS) to approved Planned Development (PD) #03-0525, consisting of multiple parcels totaling +/- 49.12 ac. The existing PD is approved for up to 239 single-family detached dwelling units and up to 15,000 s.f. of Business Professional Office (BPO) uses. There is an existing zoning condition (#5) which allows the BPO portion of the site to be developed with single-family residential uses. The applicant is requesting to allow the site to be developed with single-family attached (townhome) units in addition to single-family. There is no change in the overall maximum entitlements, as such, staff anticipates that this request will have no change in the overall trip generation potential of the subject site.

At the request of staff, the applicant modified the existing plan to reflect access which was constructed, as well as eliminate access connection within the vacant portion of the PD (folio 57481.0990) which do not meet access spacing requirements per the Land Development Code (LDC) and which otherwise cause the project to exceed the maximum number of allowable access points pursuant to Section 6.04.03.I of the LDC. Staff supports these changes. The applicant provided a transportation analysis indicating the remaining access points are not currently exceeding, nor are anticipated to exceed, the Section 6.04.04.D. LDC turn lane warrants.

**REQUESTED ADMINISTRATIVE VARIANCE**

24<sup>th</sup> St. SE is a 2-lane, undivided, substandard collector roadway which is characterized by +/- 20 feet of pavement lying within a +/- 60-foot wide right-of-way. The applicant’s Engineer of Record (EOR) submitted a Section 6.04.02.B. Administrative Variance Request (dated March 25, 2021) from the Section 6.04.03.L. LDC requirement, whereby the developer is required to improve 24<sup>th</sup> St. SE (between the project roadway and nearest roadway meeting County standards) to current County standards for a TS-4 or TS-7 collector roadway. Based on factors presented in the Administrative Variance Request, the County Engineer found the request approvable on May 25, 2021. If the rezoning is approved, the County Engineer will approve the above referenced Administrative Variance Request, upon which the developer will not be required to make improvements to the roadway.

**LEVEL OF SERVICE (LOS) INFORMATION**

<b>Roadway</b>	<b>From</b>	<b>To</b>	<b>LOS Standard</b>	<b>Peak Hour Directional LOS</b>
24 <sup>th</sup> St. SE	21 <sup>st</sup> Ave SE	SR 674	D	C

Source: Hillsborough County 2019 Level of Service Report.

## Ratliff, James

---

**From:** Williams, Michael  
**Sent:** Tuesday, May 25, 2021 6:23 PM  
**To:** Dallas Evans  
**Cc:** Defranc, Kevie; Grady, Brian; Tirado, Sheida; Ratliff, James  
**Subject:** FW: 21-0254 Administrative Variance Request  
**Attachments:** 21-0254 AVReq 04-14-21.pdf

Dallas – the attached Administrative Variance for substandard road has been input into Optix and is APPROVABLE.

Mike

### Michael J. Williams, P.E.

**Director, Development Review**

**County Engineer**

Development Services Department

---

P: (813) 307-1851

M: (813) 614-2190

E: [Williamsm@HillsboroughCounty.org](mailto:Williamsm@HillsboroughCounty.org)

W: [HCFLGov.net](http://HCFLGov.net)

---

### Hillsborough County

601 E. Kennedy Blvd., Tampa, FL 33602

---

[Facebook](#) | [Twitter](#) | [YouTube](#) | [LinkedIn](#) | [HCFL Stay Safe](#)

Please note: All correspondence to or from this office is subject to Florida's Public Records law.

---

**From:** Tirado, Sheida <[TiradoS@hillsboroughcounty.org](mailto:TiradoS@hillsboroughcounty.org)>  
**Sent:** Tuesday, May 25, 2021 5:54 PM  
**To:** Williams, Michael <[WilliamsM@HillsboroughCounty.ORG](mailto:WilliamsM@HillsboroughCounty.ORG)>  
**Subject:** 21-0254 Administrative Variance Request

We suggest approval.

Best Regards,

### Sheida L. Tirado, PE

**Transportation Review Manager**

Development Services Department

---

P: (813) 276-8364

E: [tirados@HCFLGov.net](mailto:tirados@HCFLGov.net)

W: [HCFLGov.net](http://HCFLGov.net)

---

**Hillsborough County**

601 E. Kennedy Blvd., Tampa, FL 33602

---

[Facebook](#) | [Twitter](#) | [YouTube](#) | [LinkedIn](#) | [HCFL Stay Safe](#)

Please note: All correspondence to or from this office is subject to Florida's Public Records law.



**Hillsborough  
County Florida**  
Development Services

601 E. Kennedy Blvd., 19th Floor | (813) 272 5600

# Additional / Revised Information Sheet

Received April 14, 2021  
Development Services

Date Stamp Here

Application Number: 21-0254 Applicant's Name: Dallas Evans, Agent for Applicant

Reviewing Planner's Name: Kevie Defranc Date: 04/13/2021

Application Type:

- Planned Development (PD)
  Minor Modification/Personal Appearance (PRS)
  Standard Rezoning (RZ)
- Variance (VAR)
  Development of Regional Impact (DRI)
  Major Modification (MM)
- Special Use (SU)
  Conditional Use (CU)
  Other \_\_\_\_\_

Current Hearing Date (if applicable): 05/11/2021

### The following must be attached to this Sheet.

Cover Letter with summary of the changes and/or additional information provided. If a revised Site Plan is being submitted, all changes on the site plan must be listed in detail in the Cover Letter.

An updated Project Narrative consistent with the changes or additional information provided, if applicable.

Submittal Via:

Email (Preferred). Note that no follow up paper file is necessary. Pdf format only. Maximum attachment(s) size is 15 MB.

Email this sheet along all the additional/revised submittal items in pdf to: [ZoningIntake-DSD@hcflgov.net](mailto:ZoningIntake-DSD@hcflgov.net)

Mail or delivery. Number of Plans Submitted: Large \_\_\_\_\_ Small \_\_\_\_\_

For PD, MM, PRS and SU: 7 large copies 24"X36", one small 8.5X11".  
For RZ-Standard: if plot plan is larger than 8.5"X11", 7 large copies should be submitted.  
For Minor Change: 6 large copies.  
For Variances or Conditional Use permits: one 8.5"X11" or larger)

**Mail to:**  
Development Services Department  
Community Development Division  
P.O. Box 1110  
Tampa, FL 33601-1110

**Hand Deliver to:**  
County Center  
Development Services Department  
19th Floor  
601 E. Kennedy Blvd., Tampa

*I certify that changes described above are the only changes that have been made to the submission. Any further changes will require an additional submission and certification.*

Justin D Evans

Digitally signed by Justin D Evans  
Date: 2021.04.13 20:43:53 -04'00'

04/13/2021

Signature

Date

#### FOR OFFICE USE ONLY

- Notification E-Mail Sent
  Scanned into OPTIX
- Transmittal Completed

In-Take Completed by: \_\_\_\_\_



April 13, 2021

Kevie Defranc  
Senior Planner  
Community Development Division  
Development Services Department  
Hillsborough County

RE: Bayou Pass  
PRS 21-0254  
Administrative Variance Submittal

Dear Mr. Defranc:

An administrative variance request is attached in association with PRS 21-0254. This request is also being submitted to Transportation staff via the [pw-ceintake@hcflgov.net](mailto:pw-ceintake@hcflgov.net) email. Please feel free to contact me if there are any questions regarding this submittal.

Sincerely,

*Dallas Evans*

J. Dallas Evans, P.E., AICP  
Principal Engineer





April 13, 2021

Mr. Mike Williams, P.E.  
Hillsborough County Engineer  
601 E. Kennedy Boulevard  
Tampa, Florida 33602

**Re: Bayou Pass  
PRS 21-0254  
6.04.02B Administrative Variance Request**

Dear Mr. Williams;

Thank you for meeting with us on March 8, 2021 to discuss 24<sup>th</sup> St SE as it relates to the proposed development of the remaining undeveloped BP-O parcels within the Bayou Pass subdivision. We have submitted a personal appearance request (PRS) to modify the existing Planned Development zoning to both reflect constructed access points onto the surrounding roadways and to reduce access points from the BP-O parcels. The purpose of this letter is to request a 6.04.02B Administrative Variance for the above referenced project.

24<sup>th</sup> St SE would be considered a substandard roadway, as the improvements currently constructed within the right of way do not exactly match the Hillsborough County typical section for a rural collector, as specified by the Hillsborough County Transportation Technical Manual. Typical Section TS-7 of that manual specifies that a collector roadway shall have a minimum of 96' of right of way, containing two 12' travel lanes, a 5' paved shoulder, and ditches and sidewalks on either side (refer to Exhibit 1).

Per our discussion, 24<sup>th</sup> Street SE is an existing two lane, rural section collector roadway. The posted speed limit is 45 MPH. The existing roadway consists of two 10' lanes with an unpaved shoulder. There is a 5' sidewalk constructed along the west side of the roadway adjacent to the subject property. The east side of the roadway contains a drainage ditch. The overall right of way width is approximately 73 feet per the Hillsborough County Right of Way Inventory, although it should be noted that the Right of Way Inventory appears to be misaligned within this area. The apparent right of way width is measured at 86 feet from the fence line of the National Weather Service observatory along the east side of 24<sup>th</sup> St SE to the existing fence on the subject property on the west side.

April 13, 2021  
Bayou Pass 6.04.02B Administrative Variance Request



Figure 1 - View of 24th Ave SE looking north

Section 6.04.02B lists the following criteria to be evaluated in consideration of a variance request:

- A. There is an unreasonable burden on the applicant
- B. The variance would not be detrimental to the public health, safety and welfare
- C. Without the variance, reasonable access cannot be provided

Unreasonable Burden on the Applicant

The subject site is currently entitled for the requested single family use, as well as for the proposed density. The impetus for the requested PRS is simply to allow for building forms appropriate for affordable housing development such as townhome, cottage, or zero lot line development (in keeping with the original PD, which had designated the development for affordable housing). Staff has requested that the PD be updated to reflect the constructed roadway geometry of the development as part of this PRS. The requirement to reconstruct the existing roadway simply to allow an alternate building form and to reflect existing conditions would create an unreasonable burden on the applicant.

Will Not be Detrimental to Public Health, Safety and Welfare

A search of the Signal Four Analytics database for 24<sup>th</sup> ST SE between 14<sup>th</sup> Ave SE and the underpass of I-75 reveals no crashes over the past three years.

Our firm has prepared a traffic study which predicts traffic along 24<sup>th</sup> St SE upon completion of the proposed development. That study had indicated that the roadway is expected to carry 238 southbound vehicles and 199 northbound vehicles in the PM peak hour. Per Table 7 of the

April 13, 2021  
Bayou Pass 6.04.02B Administrative Variance Request

FDOT Quality / Level of Service Handbook, a Class I roadway can carry up to 747 peak hour directional trips before dropping to Level of Service (LOS) C.

With less than a third of the number of trips which would drop the LOS below level B and considering that no accidents have been reported within this section of 24<sup>th</sup> St SE in the past three years, the expected roadway is expected to safely accommodate predicted traffic. A sidewalk exists across the project frontage to accommodate pedestrian traffic to/from the development.

Without the Variance, Reasonable Access Can Not Be Provided

As discussed above, the existing right of way is narrower than what would be required to match Typical Section TS-7. Full reconstruction of the roadway to match TS-7 is infeasible within the short distance along the subject property and would require shifting of the travel lanes which would cause a misalignment at the intersection of 24<sup>th</sup> St SE and 14<sup>th</sup> Ave SE.

Additionally, staff has indicated that a PRS would be required to reflect the location of constructed roadways, as the PD had not been updated in the past as the roadway network of the development were revised during construction plan preparation. A variance is required to allow this project to proceed to site plan review, which is a prerequisite to access of the property.

We respectfully request approval of a 6.04.02B administrative variance for the access. Please feel free to call me if you have any questions regarding this application.

Sincerely,

**Landis Evans + Partners, Inc.**

Dallas Evans, P. E.  
Principal Engineer  
PE #72691

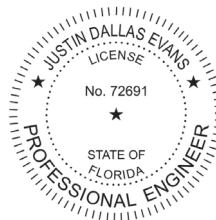

Reason: This item has been digitally signed and sealed by J. Dallas Evans, P.E., on the date shown hereon. Printed copies of this document are not considered signed and sealed and the signature must be verified on any electronic copies. Date: 2021.04.13 20:41:55 -04'00'

Based on the information provided by the applicant, this request is:

\_\_\_\_\_ Disapproved

\_\_\_\_\_ Approved

Michael J. Williams, P.E.

Hillsborough County Engineer

**COMMISSION**

Mariella Smith CHAIR  
 Pat Kemp VICE-CHAIR  
 Harry Cohen  
 Ken Hagan  
 Gwendolyn “Gwen” W. Myers  
 Kimberly Overman  
 Stacy White



**DIRECTORS**

Janet L. Dougherty EXECUTIVE DIRECTOR  
 Hooshang Boostani, P.E. WASTE DIVISION  
 Elaine S. DeLeeuw ADMIN DIVISION  
 Sam Elrabi, P.E. WATER DIVISION  
 Rick Muratti, Esq. LEGAL DEPT  
 Andy Schipfer, P.E. WETLANDS DIVISION  
 Sterlin Woodard, P.E. AIR DIVISION

**AGENCY COMMENT SHEET**

REZONING	
<p><b>HEARING DATE:</b> 03/09/2021</p> <p><b>PETITION NO.:</b> 21-0254</p> <p><b>EPC REVIEWER:</b> Chantelle Lee</p> <p><b>CONTACT INFORMATION:</b> (813) 627-2600 X 1358</p> <p><b>EMAIL:</b> <a href="mailto:leec@epchc.org">leec@epchc.org</a></p>	<p><b>COMMENT DATE:</b> 2/23/2021</p> <p><b>PROPERTY ADDRESS:</b> Ruskin, FL 33575</p> <p><b>FOLIO #:</b> 057481-0990</p> <p><b>STR:</b> 16-32S-19E</p>
<p><b>REQUESTED ZONING:</b> Minor modification to PD</p>	
FINDINGS	
<b>WETLANDS PRESENT</b>	NO
<b>SITE INSPECTION DATE</b>	N/A
<b>WETLAND LINE VALIDITY</b>	N/A
<b>WETLANDS VERIFICATION (AERIAL PHOTO, SOILS SURVEY, EPC FILES)</b>	N/A
<p><b>INFORMATIONAL COMMENTS:</b></p> <p>Wetlands Division staff of the Environmental Protection Commission of Hillsborough County (EPC) inspected the above referenced site in order to determine the extent of any wetlands and other surface waters pursuant to Chapter 1-11, Rules of the EPC. This determination was performed using the methodology described within Chapter 62-340, Florida Administrative Code, and adopted into Chapter 1-11. The site inspection revealed that no wetlands or other surface waters exist within the above referenced parcel.</p> <p>Please be advised this wetland determination is informal and non-binding. A formal wetland delineation may be applied for by submitting a “WDR30 - Delineation Request Application”. Once approved, the formal wetland delineation would be binding for five years.</p>	

Cl/mst

**WATER RESOURCE SERVICES  
REZONING REVIEW COMMENT SHEET: WATER & WASTEWATER**

---

PETITION NO.: MM21-0254      REVIEWED BY: Randy Rochelle      DATE: 1/19/2021

FOLIO NO.: 57481.0990

---

This agency would  (support),  (conditionally support) the proposal.

**WATER**

- The property lies within the Hillsborough County Water Service Area. The applicant should contact the provider to determine the availability of water service.
- No Hillsborough County water line of adequate capacity is presently available.
- A 8 inch water main exists  (adjacent to the site),  (approximately 65 feet from the site) and is located within the north Right-of-Way of 14<sup>th</sup> Street SE.
- Water distribution improvements may be needed prior to connection to the County's water system.
- No CIP water line is planned that may provide service to the proposed development.
- The nearest CIP water main (       inches), will be located  (adjacent to the site),  (feet from the site at       ). Expected completion date is       .

**WASTEWATER**

- The property lies within the Hillsborough County Wastewater Service Area. The applicant should contact the provider to determine the availability of wastewater service.
- No Hillsborough County wastewater line of adequate capacity is presently available.
- A 6 inch wastewater force main exists  (adjacent to the site),  (approximately     feet from the site) and is located within the south Right-of-Way of 14<sup>th</sup> Street SE.
- Wastewater distribution improvements may be needed prior to connection to the County's wastewater system.
- No CIP wastewater line is planned that may provide service to the proposed development.
- The nearest CIP wastewater main (       inches), will be located  (adjacent to the site),  (feet from the site at       ). Expected completion date is       .

COMMENTS: This site is located within the Hillsborough County Urban Service Area, therefore the subject property should be served by Hillsborough County Water and Wastewater Service. This comment sheet does not guarantee water or wastewater service or a point of connection. Developer is responsible for submitting a utility service request at the time of development plan review and will be responsible for any on-site improvements as well as possible off-site improvements.